

THIS DRAWING IS UNPUBLISHED.

RELEASED FOR PUBLICATION

-. - .

© COPYRIGHT - By -

ALL RIGHTS RESERVED.

LOC AF DIST 50

REVISIONS

P	LTR	DESCRIPTION	DATE	DWN	APVD
	D2	REVISED PER ECO-11-004917	11MAR11	RK	HMR

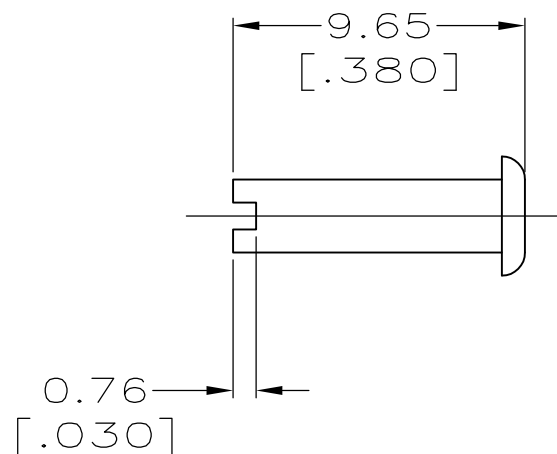
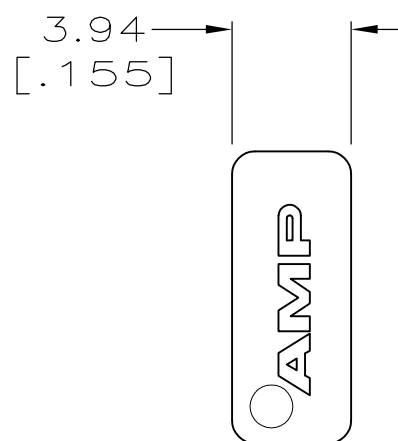
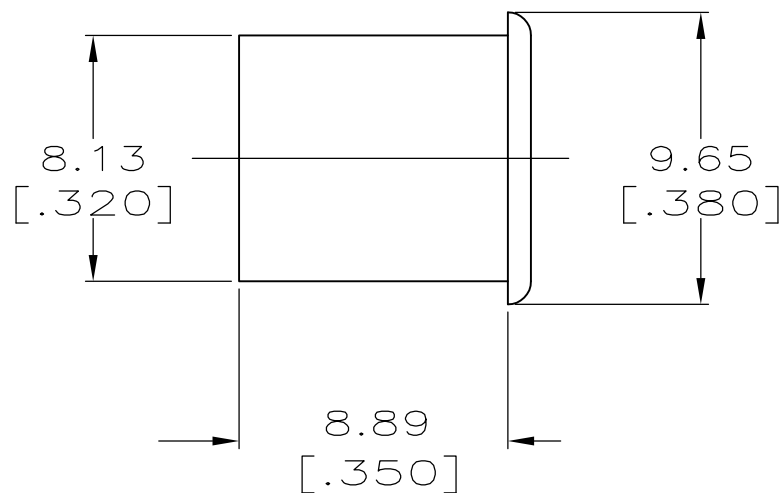
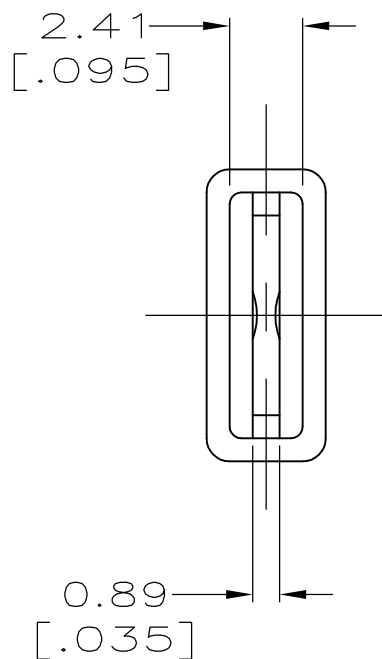

1 TO FIT ANY STANDARD 6.35 [.250] SERIES TAB 0.81 [.032] THICK.

2 PRELIMINARY - NOT FOR PRODUCTION

NATURAL	NYLON 6/6, V0	2 360042-3
BLACK	NYLON 6/6, V2	2 360042-2
NATURAL	NYLON 6/6, V2	360042-1
COLOR	MATERIAL	PART NO.

THIS DRAWING IS A CONTROLLED DOCUMENT.

DIMENSIONS: mm	TOLERANCES UNLESS OTHERWISE SPECIFIED:
	0 PLC ± -
	1 PLC ± -
	2 PLC ± 0.38 [.015]
	3 PLC ± -
	4 PLC ± -
	ANGLES ± -
MATERIAL SEE TABLE	FINISH SEE TABLE

DWN JR RUTH 12/15/98	NAME CAP, TAB, 6.35 [.250] SERIES
CHK MS FEHER 12/15/98	
APVD S UNGER 12/15/98	
PRODUCT SPEC -	
APPLICATION SPEC -	RESTRICTED TO -
WEIGHT -	SIZE A3
CUSTOMER DRAWING	CAGE CODE 00779
	DRAWING NO C-360042
	SCALE 4:1
	SHEET 1 OF 1
	REV D2

**STE** TE Connectivity